

W7212 to W7220/JADE

- Rumor is that Carrier will have access to the W7212 till the end of 2013. At that point the only option is going to be the JADE controller.
- Learning the conversion from other controllers to the JADE is going to be mandatory!



Micrometl W7212 Economizer

An existing economizer with newer style actuator

- If this were a W7459 you would need to replace the actuator as well as the controller

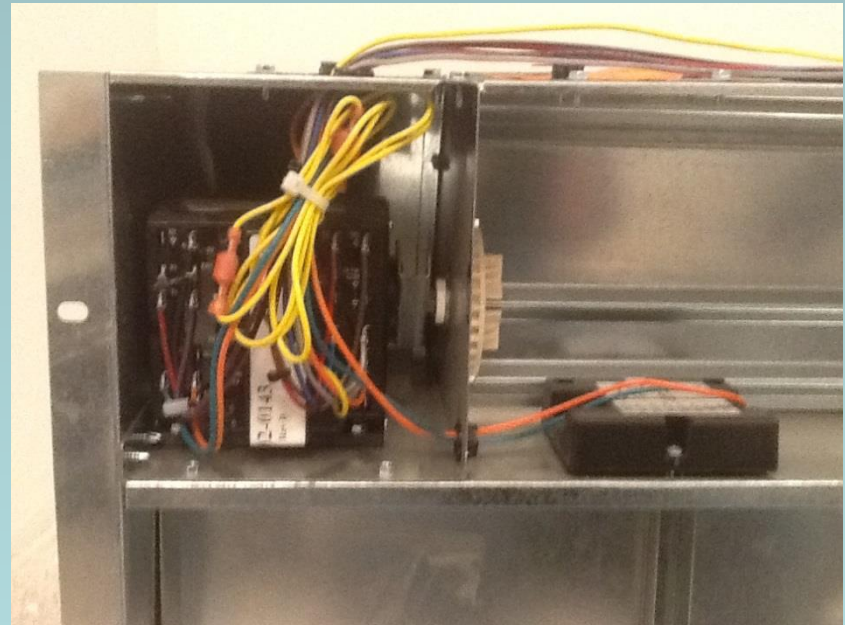

Older Honeywell Termination

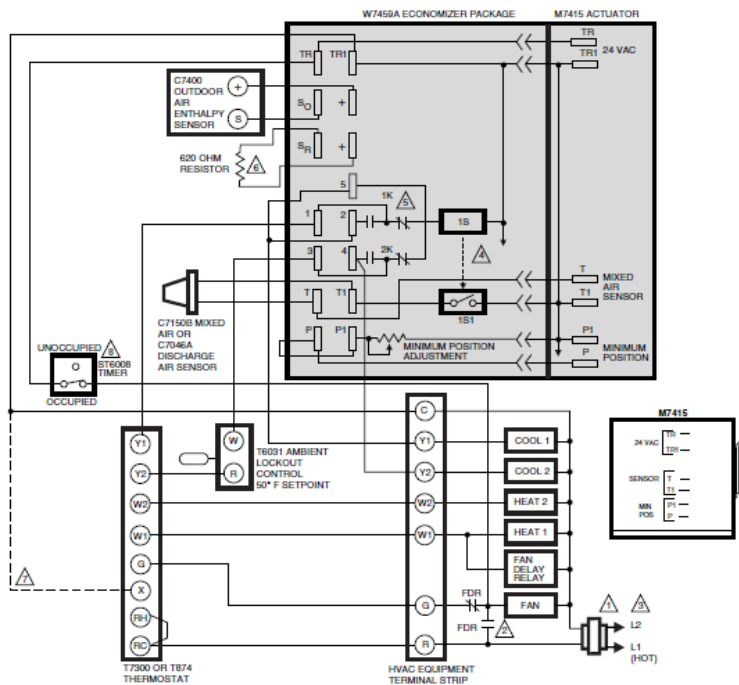

- ⚠ POWER SUPPLY. PROVIDE DISCONNECT MEANS AND OVERLOAD PROTECTION AS REQUIRED.
- ⚠ MOTOR SPRING-RETURNS CLOSED WHEN FAN IS NOT RUNNING.
- ⚠ ENSURE THAT EQUIPMENT TRANSFORMER IS SIZED TO HANDLE THE EXTRA LOAD OF THE ECONOMIZER AND ACTUATOR.
- ⚠ 1S IS AN ELECTRONIC SWITCH THAT CLOSURES WHEN POWERED BY A 24 VAC INPUT.
- ⚠ RELAYS 1K AND 2K ACTUATE WHEN THE ENTHALPY SENSED BY THE C7400 IS HIGHER THAN THE ENTHALPY SETPOINT A.D.
- ⚠ FACTORY INSTALLED 620 OHM, 1 WATT, 5% RESISTOR SHOULD BE REMOVED ONLY IF A C7400 ENTHALPY SENSOR IS ADDED TO S_R AND + FOR DIFFERENTIAL ENTHALPY.
- ⚠ FOR T7300 ONLY.
- ⚠ WITH T7300, USE CONTACTS A₁ AND A₂ INSTEAD OF S7005 TIMER.

M1015A

Fig. 5. W7459A/C7400 or W7459D/C7400 used in two-stage cooling system with single enthalpy changeover, and M7415 Actuator.

Terminals Function

- TR-24 Volts
- TR1-24 Volts Common
- 1- Y1 Call from Thermostat
- 2&5- Y1 Signal to Compressor 1
- 3- Y2 Call from Thermostat
- 4- Y2 Signal to Compressor 2
- T & T1 -Mixed Air Sensor
- SO & + -Outside Air Sensor
- P & P1 – Minimum Position

Conversion

Carrier RTU Economizer Conversion

- Understanding the wiring diagram is the biggest challenge. Once the use of each wire is known this will be easy
 - 24 volts TR
 - 24 volts com TR1
 - Y1 from stat 1
 - Y1 to compressor 2 and 5
 - Y2 from stat 3
 - Y2 to compressor 4

Conversion

24 volts

Black

24 volts com

Brown

Y1 from stat

Blue

Y1 to compressor

Gray

Y2 from stat

Yellow

Y2 to compressor

Orange

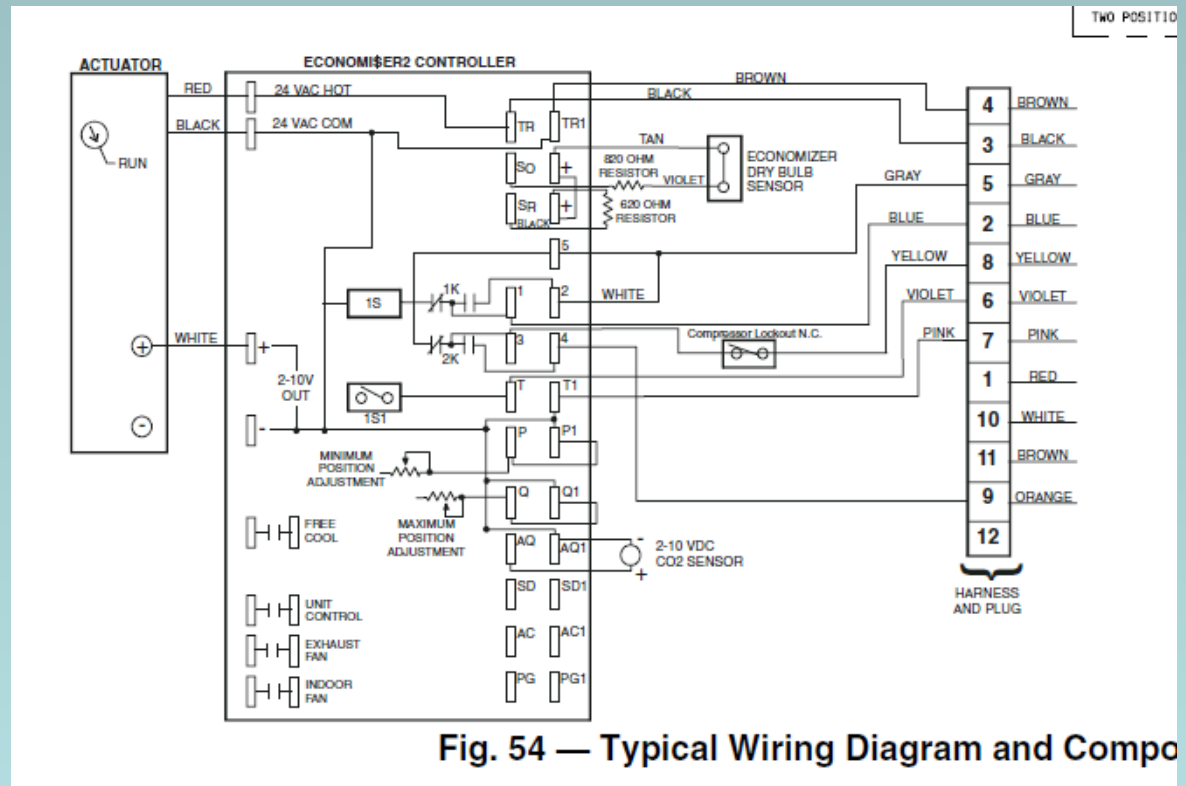

Conversion

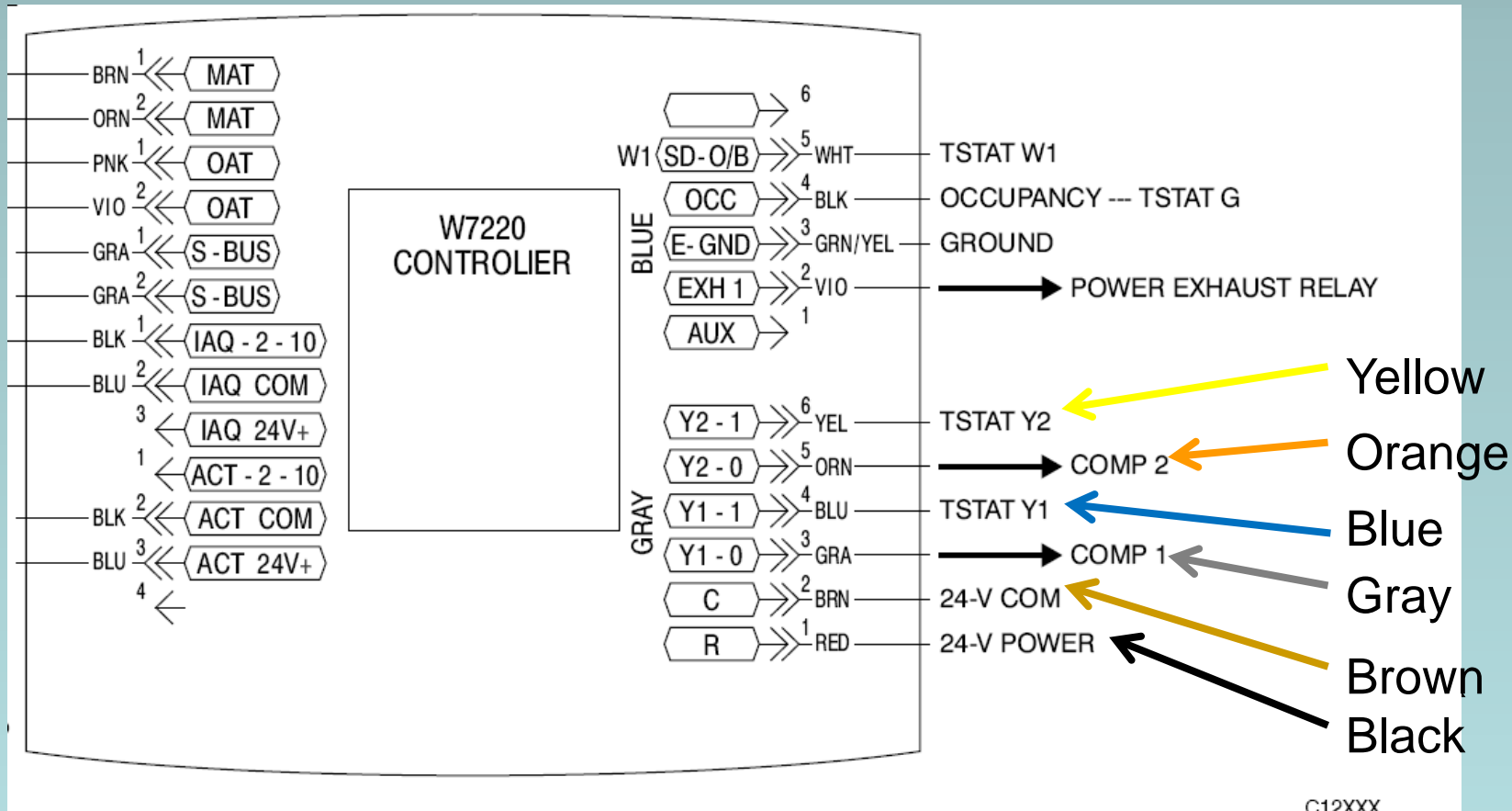

Sensors

Connect Sensors

- OAT
 - Green
 - Orange
- SAT(MAT)
 - Pink
 - Violet

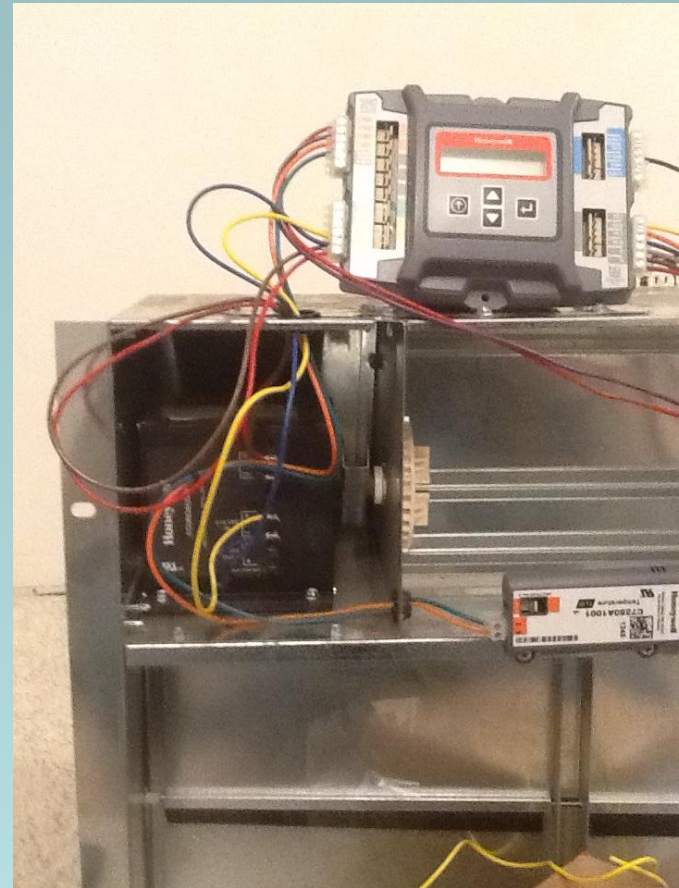

OAT Sensor

- Mount Sensor is a location for good OAT reading
- Rewire existing tow wires to new sensor
 - Not polarity sensitive

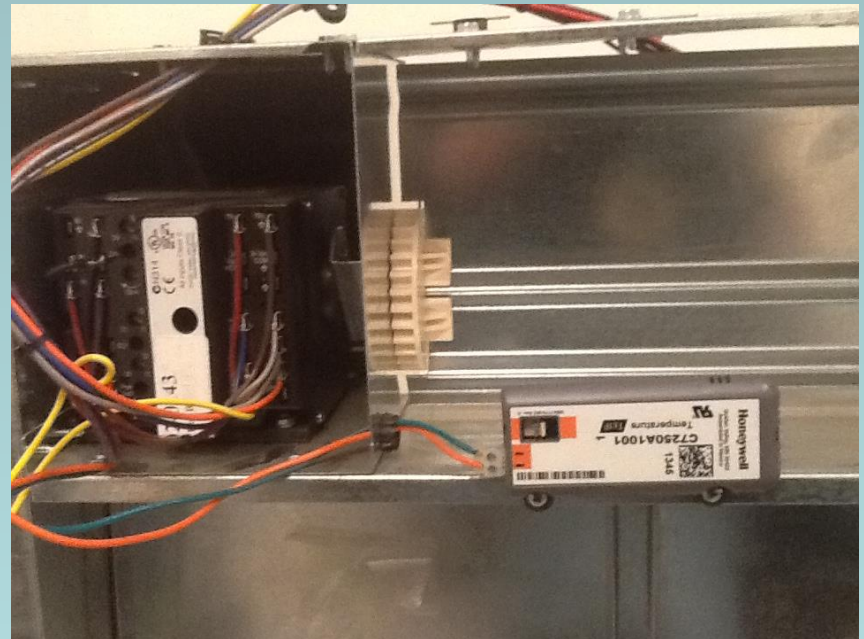

Supply Sensor

This location is really in the blower compartment and then mounted on side of blower housing

Part# C7250A 1001



Conversion

New 20K sensors with new or old wiring

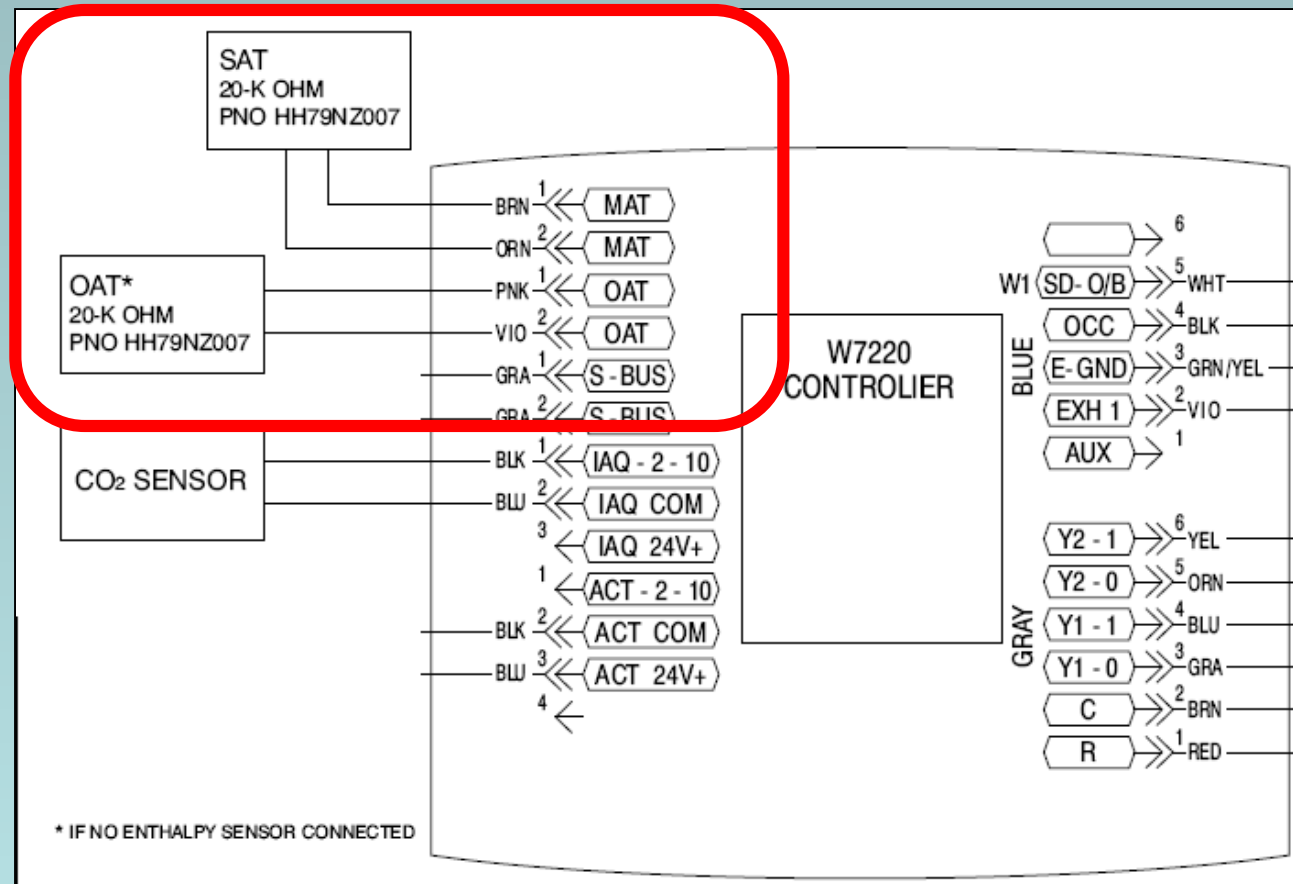

Wire Power to Actuator

- Cut the existing harness with enough wire for new sensor location
 - Starting here with the power to the actuator



Conversion

Actuator

Existing 3 wire M7215

Page 7

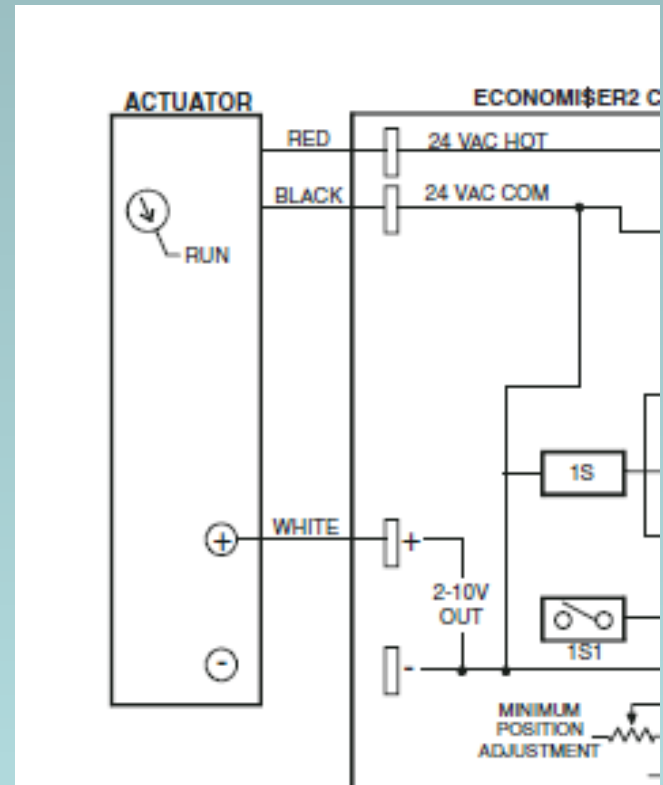
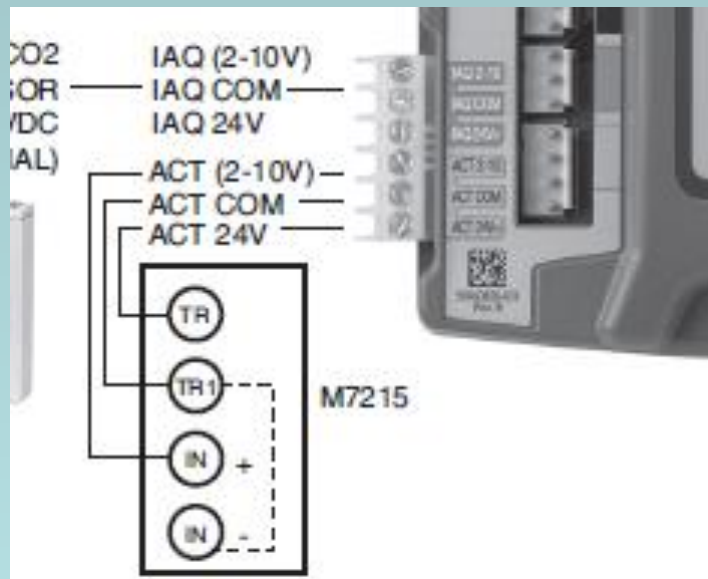

Conversion

Actuator

- If you are converting a W7459 with a M7415 you will need to replace the actuator. The W7215 is a drop in for the M7415.
- Honeywell does make kits that include all the parts needed to convert a system over

Powering the Controller

Use the unit end of harness and wire to the power inputs to the new controller



Cooling Connections

- Landing Wires:
 - Inputs for Y1(blue) and Y2(yellow)
 - Outputs to compressor Y1(gray) and Y2(Orange)

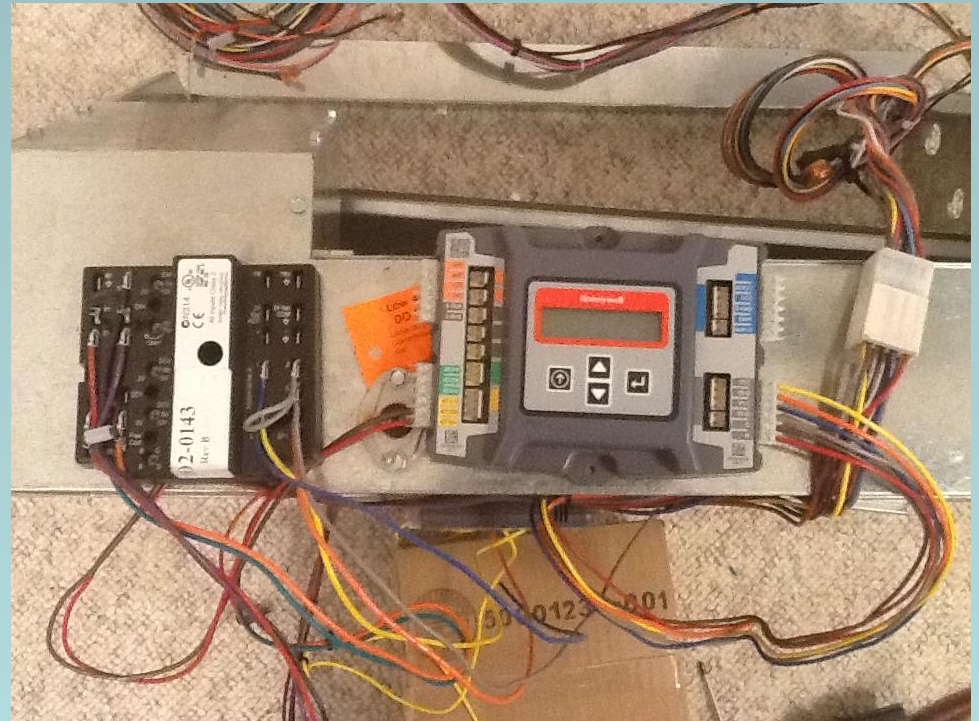

Finishing

Mount the controller in a good location

- Program
- Test
- Go to your next Service Call

